



Model: LB-II

## LEVER BLOCK LB-II SERIES

### Technical Features

- Superior Grade 80 load chain-Wafios link, Din standard.
- Forged and Heat Treated load Hooks with batch traceability and stretch indicators
- 360° handle rotation with stroke to ratchet indicators
- Double pawl Brake system
- Asbestos free Brake Linings
- Forged Safety Latch
- Sealed Roller Bearings
- 100% Load Tested to 1.5xWLL
- MBL of 400% of WLL

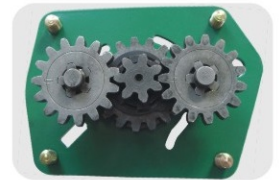
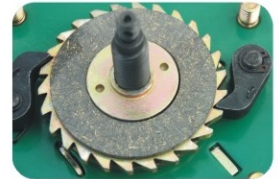

**ABLE** offers products that are designed for longtime use, providing the lowest possible per-use cost.



Hoist with the lift in extra lengths is available by extra cost upon request.

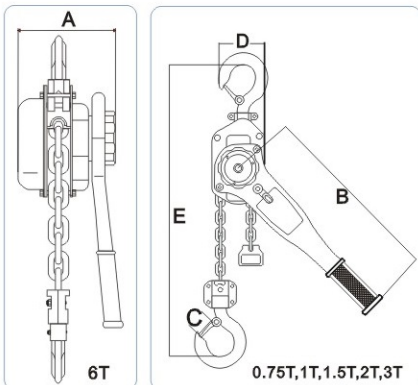

Conform & tested acc to EN 13157-2010.

Product code	Capacity Ton	Standard lift(m)	Test load Ton	Pulling Efforts kg	Chainfall NO .	Load chain Dia(mm)	Dimensions(mm)					Net weight kg
							A	B	C	D	E	
LB-II 050	0.50	1.5	0.75	10	1	6	148	280	45	96	325	5.9
LB-II 075	0.75	1.5	1.13	14	1	6	148	280	45	96	325	6.6
LB-II 100	1.00	1.5	1.50	16	1	6	148	280	48	96	325	6.8
LB-II 150	1.50	1.5	2.25	22	1	8	172	410	52	110	380	10.8
LB-II 200	2.00	1.5	3.00	26	1	8	172	410	60	110	380	11.1
LB-II 300	3.00	1.5	4.50	32	1	10	195	410	66	145	480	18.2
LB-II 600	6.00	1.5	9.00	34	2	10	195	410	80	145	480	28.1
LB-II 900	9.00	1.5	13.5	34	3	10	195	410	94	155	510	38.0

Individually proof load tested with individual serial number